



BACK  
TO SCHOOL

align front of  
class unit

## featuring:

- Sliding magnetic porcelain whiteboard doors (lockable) with internal storage behind (3 adjustable shelves)
- Lower cupboards or tote tray bay options



### assembly required.

- 2400mm wide units - supplied in three parts
- 3600mm wide units - supplied in eight parts

for safety reasons, we recommend  
that this unit is fixed to a wall.

## options:

- Lockable lower cupboards (keyed alike)
- Tote tray bays or cupboards at either end of unit
- Three sizes:
  1. 2400w x 515d x 1900h (base unit 730h)
  2. 3600w x 515d x 1900h (base unit 730h)
  3. 3600w x 515d x 2070h (base unit 900h)  
(Size 3 has option for no internal shelves on left of unit, allowing space for a digital screen to be mounted behind sliding door.)
- Four colourways:



- Tote trays (additional)



- Variations of the Align Front of Class Unit: Additional drawers and custom sizes to meet your specifications. Speak to your nearest account manager for more information.

**furnware**<sup>®</sup>

# range:



2400mmW x 1900mmH x 515mmD  
Lower cupboards 730mmH

- 2 sliding whiteboards (lockable)
- 6 cupboards



2400mmW x 1900mmH x 515mmD  
Lower cupboards 730mmH

- 2 sliding whiteboards (lockable)
- 4 cupboards
- 2 bays x 5h tote trays at each end of unit



2400mmW x 1900mmH x 515mmD  
Lower cupboards 730mmH

- 2 sliding whiteboards (lockable)
- 1 open shelf on right end of unit
- 5 bays x 5h tote trays

*\* Sliding whiteboards not pictured*



3600mmW x 1900mmH x 515mmD  
Lower cupboards 730mmH

- 2 sliding whiteboards (lockable)\*
- 8 cupboards

*\* Sliding whiteboards not pictured*



3600mmW x 1900mmH x 515mmD  
Lower cupboards 730mmH

- 2 sliding whiteboards (lockable)\*
- 6 cupboards
- 2 bays x 5h tote trays at each end of unit

*\* Sliding whiteboards not pictured*



3600mmW x 1900mmH x 515mmD  
Lower cupboards 730mmH

- 2 sliding whiteboards (lockable)\*
- Single cupboard each end
- 8 bays x 5h tote trays

*\* Sliding whiteboards not pictured*



**Tall unit**  
3600mmW x 2070mmH x 515mmD  
Lower cupboards 900mmH

- 2 sliding whiteboards (lockable)\*
- Screen space behind whiteboards
- 8 cupboards

*\* Sliding whiteboards not pictured*



**Tall unit**  
3600mmW x 2070mmH x 515mmD  
Lower cupboards 900mmH

- 2 sliding whiteboards (lockable)\*
- 8 cupboards

*\* Sliding whiteboards not pictured*

# align front of class unit - 2400 wide.

## assembly instructions.



You have received **three** packages, including:

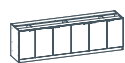

1 x Front of Class Unit Base

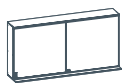

1 x Front of Class Unit Top



2 x Front of Class Unit Sides



12 x Surefix Screws - Square  
24 x Titus Hilo Screws - Phillips



24 x Cover Caps

You will need:



Impact Driver  
SQZ Driver bit □  
Pozi Driver Bit ⊕

**Please note:** If you have ordered multiple Front of Class Units, all three packages for the same unit will be identified with the same letter, (e.g. Unit A). Wall fixing hardware not included.

### Step 1

Use multiple people to lift the Front of Class Unit Base to its final location. We recommend the unit is fixed to a wall for safety reasons.

### Step 2

Use multiple people to lift the Front of Class Unit Top onto the Base, ensuring the sides and back of the Base and Top are flush and aligned.

### Step 3

Fasten the Unit Top to the Unit Base by inserting the provided Surefix screws into the pre-drilled holes in the underside of the Unit Base rails and tightening.

### Step 4

Fasten the Unit Sides to the pre-assembled Base and Top by inserting the Titus Hilo screws provided into the pre-drilled holes in the sides of each unit and fastening. Cover screw heads with the Cover Caps provided.

### Steps 2 & 3

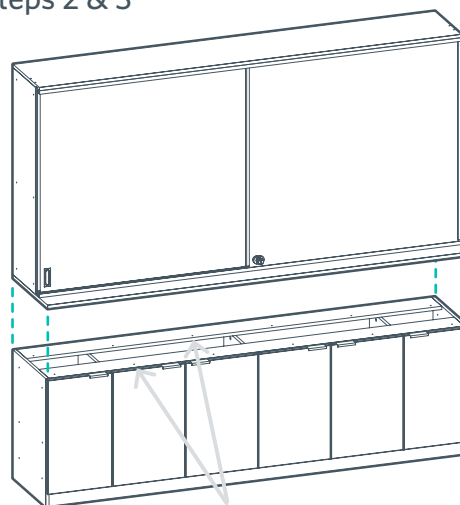

Insert 12 x Surefix screws in front and back rails

### Step 4

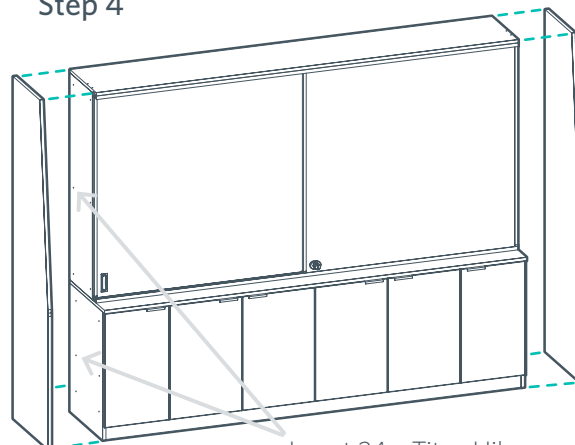

Insert 24 x Titus Hilo screws in both sides of the Unit Base and Top

# align front of class unit - 3600 wide.

## assembly instructions.

You have received **eight** packages, including:

You will need:

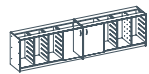

2 x Front of Class Unit Bases (A and B)

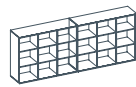

2 x Front of Class Unit Tops (A and B)



2 x Front of Class Unit Sides

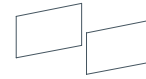

2 x Whiteboard Doors



Impact Driver  
SQZ Driver bit □  
Pozi Driver Bit +



1 x Top Aluminium track  
2 x Bottom Aluminium tracks  
4 x "L" Brackets (screwed into bottom track)



20 x Surefix Screws - Square  
36 x Titus Hilo Screws - Phillips  
40 x Whiteboard Screws - Square



36 x Cover Caps

**Please note:** If you have ordered multiple Front of Class Units, all eight packages for the same unit will be identified with the same letter, (e.g. Unit A). Wall fixing hardware not included.

### Step 1

Position Front of Class Unit Bases A and B into their final location and fasten together with Titus Hilo screws, using pre-drilled holes.

Tip: Fix Front of Class Unit Bases to wall prior to step 2.

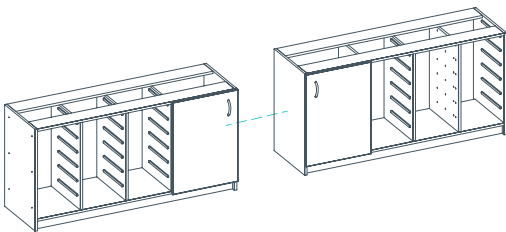

### Step 2

Place Unit Tops A and B on top of the Unit Base, ensuring sides and back are aligned. Fasten together by screwing through the top of the Unit Base with Surefix screws, using pre-drilled holes.

Tip: Fix Front of Class Unit Tops to wall prior to step 3.

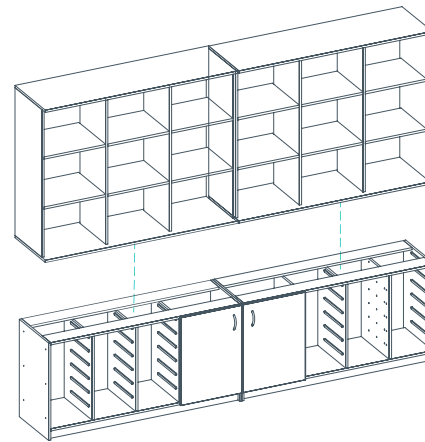

### Step 3

Screw aluminium track into place with Whiteboard screws, using pre-drilled holes (highlighted red items in drawing).

Slide Whiteboard Doors onto tracks, ensuring lockable door is at the front.

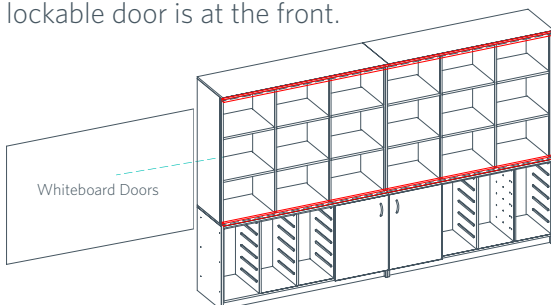

### Step 4

Once Whiteboard Doors are in place, screw on both Unit Sides using pre-drilled holes with 24 x Titus Hilo Screws. Cover screw heads with Cover Caps.

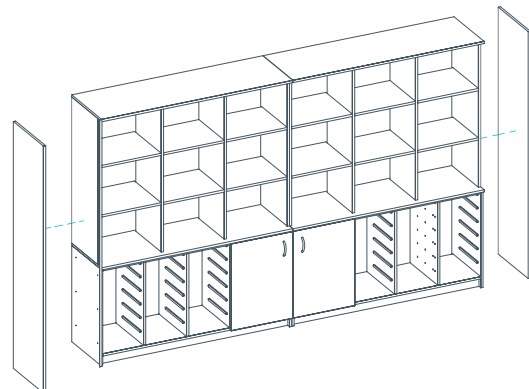

get in touch.



**tony o'sullivan**  
+64 21 951 382  
tony.osullivan@furnware.com



**rebecca king**  
+64 27 337 9539  
rebecca.king@furnware.com



**eza murray**  
+64 27 464 0086  
eza.murray@furnware.com



**tim curtis**  
+64 21 482 298  
tim.curtis@furnware.com



**marianne elliot**  
+64 21 753 302  
marianne.elliott@furnware.com



**ian johnstone**  
+64 21 382 239  
ian.johnstone@furnware.com



**kyle cooke**  
+64 27 627 4261  
kyle.cooke@furnware.com